



SMPR-1

Current - Voltage - Power
Measurement & Protection Relay



Summarize Measurement and Protection Relay

DESCRIPTION

The SMPR-1 has been designed to measure the line and the ground RMS currents and supply RMS voltages under normal conditions or under disturbances. This information is internally processed by the microprocessor, to take the protection actions defined by the user under ANSI, IAC or IEC standards. The operational conditions of the breaker or disconnector are also signalized

APPLICATIONS

- Primary and backup protections for power plants, utility and industrial distribution systems.
- Protection of transformers, overhead lines, cables and generators.
- Allows the opening of the switch/disconnector within the limits of its capacity, leaving the circuit interruption to the back-up fuses in case of short circuit.

PROTECTION AND FUNCTIONALITY

- **(27)** Undervoltage.
- **(46)** Negative sequence current [on request].
- **(49)** Thermal image [on request].
- **(50)** Instantaneous phase overcurrent.
- **(50N/50G)** Instantaneous ground overcurrent.
- Overload alarm pickup level.
- **(51)** Inverse time phase overcurrent
- **(51N/51G)** inverse time ground overcurrent,
- ANSI, IAC or IEC/BS142 curves included:
 - Moderately inverse
 - Normal inverse
 - Very inverse
 - Extremely inverse
 - Definite time
- **(55)** Power factor.
- **(59)** Overvoltage.
- **(59N)** Homopolar voltage [on request].
- **(67/67N)** Directional phase/ground overcurrent [on request].
- **(79)** Automatic reclose [on request].
- **(81)** Underfrequency and Overfrequency.
- Accumulated KA per phase on breaker interruption.

COMMUNICATION

- Remote communication using a PC or PLC by RS422 or RS485.
- Remote programming of the setpoints.
- Remote breaker opening or closing.

FEATURES

- CT primary ratio selectable in 5 A steps (10 to 5000 A).
- Touchpad programming.
- 1 trip relay and 1 alarm relay.
- 1 breaker close relay.
- Power loss or internal fault control relay.
- 4 digital inputs: breaker status, breaker earthed, external reset and input 1).
- Breaker operation failure alarm on trip command.

SIGNALLING AND DIGITAL MEASUREMENT

- LED and LCD display indication.
- Last trip cause and relative data.
- Indication and storage of fault condition and their values.
- Indication of the breaker or disconnector status (open, close, earthed)
- RMS line and ground currents.
- Maximum instantaneous line and ground currents.
- RMS line or phase voltages.
- Active power (kW), reactive power (kvar) and apparent power (kVA).
- Active energy (MWh) and reactive energy (Mvarh).
- Power factor and system frequency.
- Positive and negative real power (kW) and reactive power (kvar).
- Running and maximum demand: current per phase (A), real power (kW), reactive power (kvar) and apparent power (kVA).

APPLICABILITY

<i>Systems:</i>	3 and 4 wire three phase systems
<i>Frequency</i>	50 and 60 Hz
<i>Current:</i>	5000 A maximum
<i>Voltage:</i>	69 kV maximum



SPECIFICATIONS

SUPPLY VOLTAGE 24±310 Vdc, -15%,+10% 24±240 Vac, -15%, +10%	MAX POWER CONSUMPTION 12 VA (7W)
TEMPERATURE RANGE Operational: 0 °C ÷ 50 °C Storage: -20 °C ÷ 70 °C	RELATIVE HUMIDITY Max. 90% (non condensing)
DIELECTRIC WITHSTAND VOLTAGE 2 kVac, 60 s	BURN IN 48 hours at 50°C
CONSTRUCTION According to VDE, UL, CEI standards	OUTPUT CONTACT <i>Rated load:</i> 8 A DC 150W resistive or 90W inductive (L/R=40 ms) AC 2000VA resistive or 800VA inductive (PF=0.4) <i>Max. operating voltage:</i> 250 Vac, 125 Vdc
COMMUNICATIONS <i>Type:</i> RS422 4-wire or RS485 2-wire, half duplex, 1200 → 9600 baud <i>Protocol:</i> Modbus RTU <i>Functions:</i> Read/Write setpoints Read actual values Execute commands	LED INDICATORS <i>Relay status:</i> trip, alarm, service <i>System status:</i> breaker closed, breaker open, breaker earthed, switch current <i>Display (LCD):</i> 16 x 2 digits
DIGITAL INPUT <i>Type:</i> Dry contact only, 500 Ohm max ON resistance <i>Output:</i> 12 Vdc @ 10 mA provided by relay	TERMINAL BLOCK Fixed, back connection terminals with 4-mm ² section cable (12 AWG)
FRAME In ABS auto-extinguish with frontal in polycarbonate (IP54)	ASSEMBLY The relay has to be jointed to the structure by the use of two stirrups with screws.
DIMENSION 144 x 144 x 141 mm WEIGHT 1.5 kg	FRONT PANEL CUTOUT 137 x 137 mm
PHASE AND GROUND CT INPUTS <i>Source CT (In):</i> 10 ÷ 5000 A, steps: 5A <i>CT secondary:</i> 1 A or 5 A (must be specified with order) <i>Sensing:</i> True RMS; 12 sample/cycle <i>Bandwith:</i> 0 ÷ 100 Hz <i>CT burden:</i> 0.25 VA per phase at rated secondary current <i>Continuous:</i> 10 A <i>Current withstand capacity:</i> 20 times In current value for 1s	DISPLAY ACCURACY <i>Load current:</i> ± 1% at 100% In <i>System voltage:</i> ± 1% at 100% Un TIME OVERCURRENT CURVES Phase and Ground: ANSI, IAC, or IEC Moderately Inverse, Normally Inverse, very Inverse Extremely Inverse, Definite Time Curves apply up to 20 x pickup or 20 x In, whichever is less.
INVERSE-TIME PHASE OVERCURRENT (51) <i>Pick up level:</i> 8±250% of CT, steps of 1% <i>Time multiplier:</i> 10 curves 1-10 for each shape, shift multiplier: 0.5 to 1.1 <i>Reset:</i> Time reset to zero each time current level falls belows pickup threshold <i>Accuracy:</i> Pickup: ±3% of setting Time: Less than ±3% or ±20 ms at >150% of pickup	INVERSE-TIME GROUND CURRENT (51G/51N) <i>Pick up level:</i> 4±150% of CT, steps of 1% <i>Time multiplier:</i> 10 curves 1-10 for each shape, shift multiplier: 0.5 to 1.1 <i>Reset:</i> Time reset to zero each time current level falls belows pickup threshold <i>Accuracy:</i> Pickup: ±3% of setting Time: Less than ±3% or ±20 ms at >150% of pickup
INSTANTANEOUS GROUND OVERCURRENT (50G/50N) <i>Pickup level:</i> 1 to 18 times phase pickup, steps of 0.5 <i>Accuracy:</i> Pickup: ± 3% of setting Time: 35 ms max. at > 150% of pickup setting; <i>Saturation:</i> $\text{pickup} \leq 100\% \Rightarrow 20 \times$ programmed pickup level $\text{pickup} > 100\% \Rightarrow 20 \times \text{In}$	INSTANTANEOUS PHASE OVERCURRENT (50) <i>Pickup level:</i> 1 to 18 times phase pickup, steps of 0.5 <i>Accuracy:</i> Pickup: ± 3% of setting Time: 35 ms max. at > 150% of pickup setting; <i>Saturation:</i> $\text{pickup} \leq 100\% \Rightarrow 20 \times$ programmed pickup level $\text{pickup} > 100\% \Rightarrow 20 \times \text{In}$

VOLTAGE INPUT <i>PT input:</i> 55 to 254 Vac secondary, steps of 1 V Un: 0.10 to 69 kV primary, steps of 0.01kV <i>PT burden:</i> 1 VA max; <i>Max. continuous:</i> 320 Vac phase-neutral	POWER FACTOR PROTECTION Power factor alarm & trip <i>Pickup:</i> 0.05 Lag to 1.00 Lag; steps of 0.01 0.05 Lead to 1.00 Lead; steps 0.01 <i>Delay:</i> 0.1 to 25.4 s; steps 0.1s <i>Accuracy:</i> ± 0.1
UNDERVOLTAGE PROTECTION Undervoltage alarm & trip <i>Pickup:</i> 50 to 100% Un, steps of 1%; <i>Delay:</i> 0.1 to 25.4 s, steps of 0.1 s <i>Phase:</i> All three	OVERVOLTAGE PROTECTION Overvoltage alarm & trip <i>Pickup:</i> 101 to 125% Un, steps of 1% <i>Delay:</i> 0.1 to 25.4 s, steps of 0.1 s <i>Phase:</i> All three
UNDERFREQUENCY PROTECTION Underfrequency alarm & trip <i>Pickup:</i> 47.0 to 60.0 Hz, steps of 0.1 Hz <i>Delay:</i> 0.1 to 25.4 s, steps of 0.1 s <i>Accuracy:</i> ±0.1 Hz <i>Measured:</i> across Phase A-N or A-B voltage	OVERFREQUENCY PROTECTION Overfrequency alarm & trip <i>Pickup:</i> 50 to 63.0 Hz, steps of 1 Hz; <i>Delay:</i> 0.1 to 25.4 s, steps of 0.1 s <i>Accuracy:</i> ± 0.1 Hz <i>Measured:</i> across Phase A-N or A-B voltage
DEMAND MONITORING Accuracies based on less than 2 x In and 125% Un inputs. <i>Measured value:</i> Phase A, B, C Currents (A), 3f Real Power (kW or MW), 3f Reactive Power (kvar or Mvar) and 3f Apparent Power (kVA or MVA). <i>Measurement type:</i> Block interval (programmable) 5 to 60 min; steps of 1min. <i>Measuring ranges:</i> Current = 10 to 10,000 A; steps of 5 A Real Power = 10 to 650,000 kW; steps of 10 kW Reactive Power = 10 to 650,000 kvar; steps of 10 kvar Apparent Power = 10 to 650,000 kVA: steps of 10 kVA <i>Accuracy:</i> ±2% of full scale (1 x In at 1 x Un)	MEASURED PARAMETERS Accuracies based on 100% In and 100% Un inputs. <i>Current:</i> Phase A, B, C currents; Accuracy: ±1% of full scale. <i>Voltage:</i> A-N (A-B) / B-N (B-C) / C-N (C-A) Voltages Accuracy: ±1% F.S. <i>Frequency:</i> Across Phase A-N or A-B voltage Range: 47.0 to 63.0 Hz; Accuracy: ±0.1 Hz <i>3f Real Power:</i> Range: -1000 to 1000 MW; Accuracy: ±2% F.S. <i>3f reactive Power:</i> Range: -1000 to 1000 MVAR; Accuracy: ±2% F.S. <i>3f Apparent Power:</i> Range: 0 to 1500 MVA; Accuracy: ±2% F.S. <i>3f Power Factor:</i> Range: 0.00 Lag to 1.00 to 0.00 Lead; Accuracy: ±1% <i>Watthours:</i> Total, 1 hour. Range: 0 to 4200 GWhr; Accuracy: ±3% F.S. <i>Varhours:</i> Total, 1 hour. Range: 0 to 4200 GVArh; Accuracy: ±3% F.S. <i>Demand:</i> Metered valued: → demand monitoring Range: 0 to 1000 MW; 0 to 1000 MVAR; 0 to 1500 MVA.
IMMUNITY TEST <ul style="list-style-type: none"> • <u>Conducted disturbances induced by RF field</u> References: EN 61000-4-6; Port: AC mains and signal lines • <u>Radiated electromagnetic field</u> References: EN 61000-4-3; Port: enclosure • <u>Electrostatic discharge</u> References: EN 61000-4-2; Port: enclosure • <u>Fast transients (burst)</u> References: EN 61000-4-4 ; Port: AC mains and signal lines • <u>Surge</u> References: EN 61000-4-5 ; Port: AC mains • <u>Voltage dips and short interruptions</u> References : EN 61000-4-11 ; Port: AC mains 	EMISSION TEST <ul style="list-style-type: none"> • <u>Radiated emissions</u> References: EN 55011; Port : enclosure; Class A, at 10m • <u>Conducted emissions</u> References: EN 55011; Port: AC mains; Class A

WIRING DIAGRAM

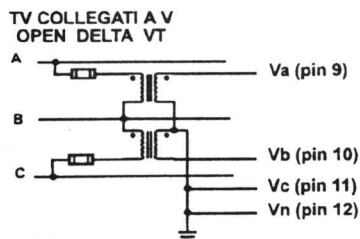
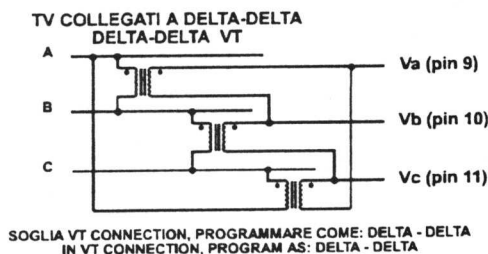
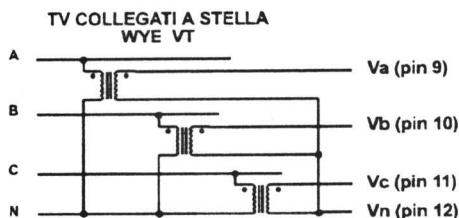
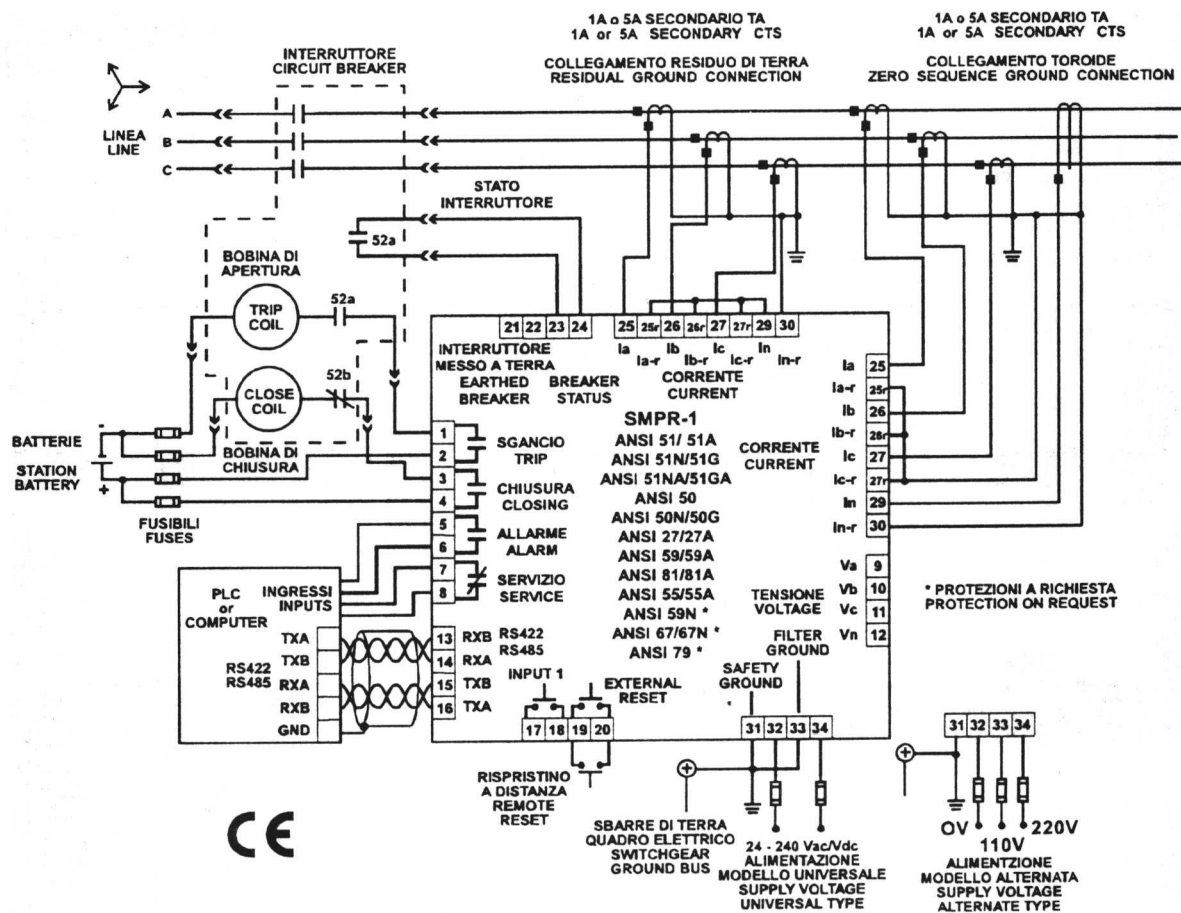

ORDER CODE: PFSMPR - 1 X X X

PHASE CT SECONDARY

- 1: 1Amp CTs
- 5: 5 Amp CTs

GROUND CT SECONDARY

- 1: 1Amp CTs
- 5: 5 Amp CTs

PROTECTIONS

- 1: 51/50 + 51/50 N/G + 59 + 27 + 81 + 55
- 2: 51/50 + 51/50 N/G + 59 + 27 + 81 + 55 + 59N
- 3: 51/50 + 51/50 N/G + 59 + 27 + 81 + 55 + 59N + 67/67N
- 4: 51/50 + 51/50 N/G + 59 + 27 + 81 + 55 + 59N + 79
- 5: 51/50 + 51/50 N/G + 59 + 27 + 59N + 67/67N + 49 + 46



Quality certified ISO 9001:2000

ORION ITALIA Srl
Via G. Orsi 35, 29100 Piacenza [PC] - Italia
Phone: + 39 0523591161 - Fax: + 39 0523593898 - www.orionitalia.com